



# **DETECTION OF SUSPICIOUS ACTIVITY IN ATM USING DEEP LEARNING**

**N.R.Sathis Kumar<sup>1</sup>, T.Nirmalraj<sup>2</sup>**

AP/ECE, Department of Electronics and Communication Engineering,  
Agni College of Technology , Thalambur.

**Abstract-**In our daily life, we see a lot of crimes and theft taking place which are not known properly. The major crimes are happening at the ATM. Developing number of securities and cops isn't effective answer to conquer the existing issue on the ATMs that the general population who are not engaged with criminal exercises who will not feel free to use ATMs and social services. In this paper, we use image processing techniques to detect the abnormal events that occur in the ATM. Images or videos taken is proposed for monitoring and detecting the abnormal events based on real time image processing techniques. The operations are carried out using two processing units, first processing unit is for implementation of real time image processing techniques and second processing unit will handle the rest of controlling, monitoring and alarm operations. This will be great help for the cops and public people to be aware of the crime scenes.

**KEYWORDS:** ATM, Image processing, real time, microcontroller, crime, abnormal events.

## **LINTRODUCTION:**

Detection of crimes and abnormal events are very difficult. Prediction of a crime scene can ease the job of law enforcement agencies. We see a lot of CCTV cameras being installed to monitor a certain area. But, the increasing number of CCTV cameras is problematic, as we need to monitor all the cameras manually. So we use the image processing techniques to detect the abnormal activities that occur in the ATMs.

Life would be easier if computers can predict crime scene by processing CCTV camera's video. The increasing demand of artificial intelligence (AI) in the security sector is a must because they can be used to train the machines with normal and the abnormal activities. According to the news published in times of India, the detective department claimed to crack the great Kolkata ATM fraud case with the arrest of a Romanian after a dramatic auto chase through Delhi lanes. The arrest came only exactly eight days after the gang struck in the city and siphoned the money from the accounts of over 71 ATM users.

As Deep Neural Network which is also known as deep learning can give outstanding performance on image classification focused on the problems of object localization in the image and automatically detects the objects in the ATM. It is easy to detect the crime when we use the deep learning techniques. The neural network is used for weapon detection in the ATM.

Automatic feature representation gives better performance than manual feature and unsupervised approach can give very close results to supervised approach. Using the MATLAB algorithm, we can detect the images of the weapon. The images or videos are processed by Mat lab using Digital Image Processing Toolbox for monitoring and detecting the abnormal events at ATM's. The Image



Processing technology is being used for military, agriculture, aerial photography, surveillance, remote sensing and many more purposes.

The operations are classified into two processing units, first processing unit is for implementation of real time image processing techniques and second processing unit will handle the rest of controlling, monitoring and alarm operations. Using the first processing unit, the abnormal activity is detected and sent to the microcontroller. The buzzer interfaced with the microcontroller will produce the sound if any abnormal activity is detected.

In this paper, we are going to discuss on various section as follows. Section II describes about the Literature survey, section III proposed system, section IV gives the conclusion and section V comprises of the references used.

## II.LITERATURE SURVEY:

Most of the crime activities are highly related with ATMs. Although the ATM is equipped with surveillance monitor, the criminals can usually break it down and Rob the money by occluding their faces. In the previous model head location method is used to detect the human face. These methods are low computational cost and accuracy. This method is consisting of three cascaded parts. They are foreground extraction, initial location and ellipse filling.

The drawback of previous system is first accuracy is very low second the pores, sizes and number of human faces can vary continuously in seconds third the background is changing all the time in videos sequences.

To overcome these problems we propose the system based on the digital image processing where the image or videos are detect or monitoring using deep learning method. In this project we can able to detect thousands or lack of images. In our method the camera are monitoring the real time activities. When the abnormal activities or unwanted objects like hammer, knife are detected it will alarm to alert the people.

This paper uses microcontroller for the purpose of alarm system. The knife, hammer and the firing equipments are considered as the unwanted equipments in the ATMs. Simultaneously when the alarm is activated the mail or massage are sent to the control room of the nearest police station to avoid the financial loss. This project will greatly improve the financial security and it also increase the accuracy and efficiency .The main aim of this model is to avoid the financial loss using alarm operation.

## III.PROPOSED SYSTEM:

We proposed a robust computer vision approach for identifying abnormal activity at public premises in real time. The proposed System is based on the digital image processing. The objective of proposed system is to detect the images and videos using deep learning method. The working principle is based on computer vision, artificial intelligence and control system.

The camera will monitor the real time activities. The input video is captured by the camera. The video is converted into the frames using image processing technique. The pre-processing block performs segmentation process to improve intensity and enhance the image .The WLS filter is weighted least square filter which is used to remove the distortions in the image and smoothen the edges of the image.

The HDR tone mapping is used to convert the image into the tonal value. The next process is object detection. Object detection is about whether the object is present or not. In object detection the detected pattern is compared with the predefined pattern to find the object .Object recognition is about to find the image whether it is a human or like car, animal etc.

The identification of object is carried out by using machine learning technique. The microcontroller is

using for the purpose of alarm system. The sound sensor and buzzer are connected with the microcontroller. The alarm is activated when the abnormal activities are detected it help in alert the public to secure them and also prevent the crime occurrence.

#### IV.BLOCK DIAGRAM:

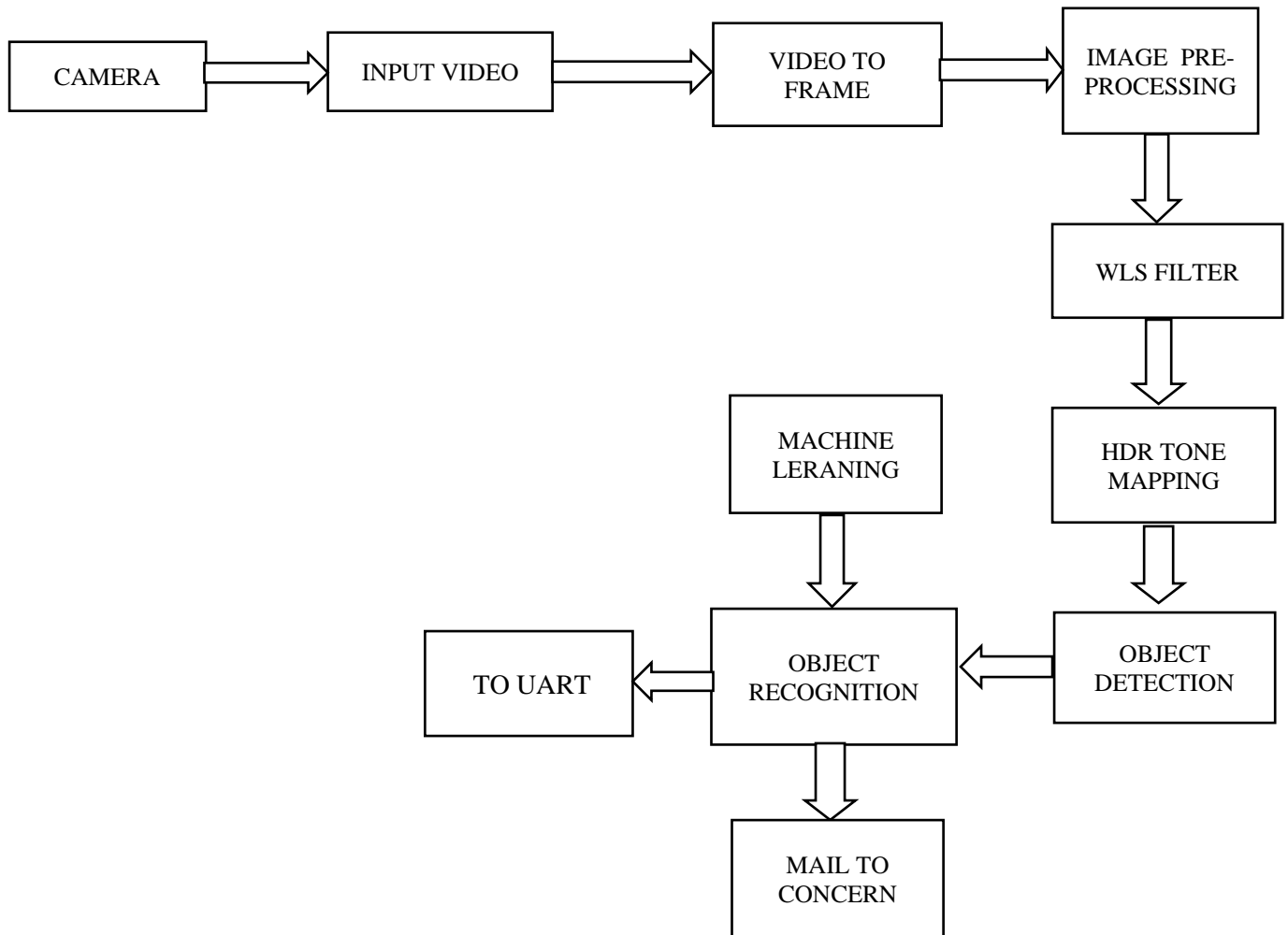

4.1 Block diagram of detection and recognition of object

The input video is converted into single images for pre-processing. It is the important step in image processing where it converts the image in a proper format for further steps. Pre-processing stage involves the re-sizing, de-noising, segmentation and smoothening of images. Pre-processing is a common name for operations with images at the lowest level of abstraction in which both input and output are intensity images. It is used for improvement of images by reducing the distortions and enhances the image for further processing.

The smoothening of the pixels is carried out by weighted least squares filter. To achieve the optimal contrast based on weak textures and colour saturation this paper aims to use the weighted least square filters. Tone mapping is a digital image processing technique in which one set of colors is

mapped to another in order to create high dynamic range. Object detection defines the object. It deals with the detection of semantic class of the objects.

Deep Learning is used to train the computer or device to differentiate the abnormal and normal activities. Object recognition identifies whether the object is present or not. It is the outcome based on the deep learning. The goal is to teach a computer to do what naturally the human does. It trains to gain a level of understanding of what an image contains. The image captured during the abnormal event is mailed to the concern.

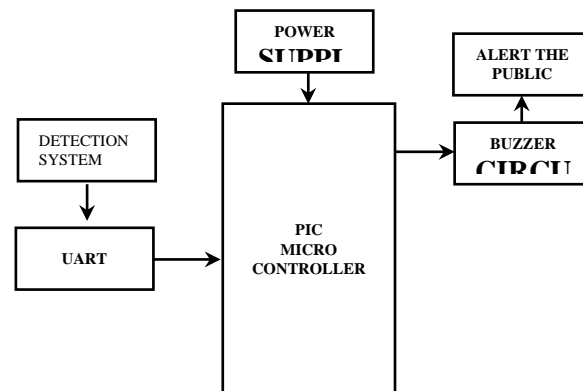

4.2 Block diagram of microcontroller

The detected information is then passed to the microcontroller through UART cable. UART is the most common method of asynchronous serial communication between two devices. The buzzer produces the sound when the abnormal activity is detected. This is used to alert the public.

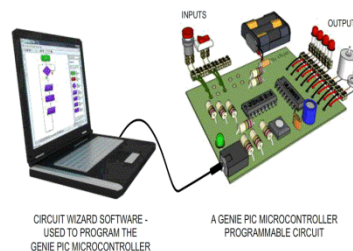

4.3 Diagram of alert system

## V. ADVANTAGES OF THE PROPOSED SYSTEM:

1. Best results with unstructured data.
2. Efficient at delivering high quality results.
3. More number of images can be processed.
4. Prevent the Crime Occurrence.
5. Considerably reduce the number of crime activities.
6. Create a Secured society

#### **VI.CONCLUSION:**

In this paper, we present an approach which can be used to easily detect the abnormal activities. The alert system is very efficient in making the public aware of the crime activities. The wrong alert of the normal activities is also reduced as we use real time techniques. The proposed model use deep learning techniques which produces better performance of the system.

#### **VII.FUTURE SCOPE:**

In future, this paper can be further developed to detect an abnormal events that occur in the ATM and deep learning can be employed to train many number of objects so that we can detect it.

#### **REFERENCES**

- [1]M.-A. Slamani and D. D. Ferris Jr, "Shape-descriptor-based detection of concealed weapons in millimeter-wave data," *Opt. Pattern Recognit.* XII, vol. 4387, pp. 176–185, 2001.
- [2] H. Pourghassem, O. Sharifi-Tehrani, and M. Nejati, "A novel weapon detection algorithm in X-ray dual-energy images based on connected component analysis and shape features," *Aust. J. Basic Appl. Sci.*, vol. 5, pp. 300–307, 2011.
- [3] M. R. Calo, "Robots and Privacy,(2011) in *Robot Ethics: The Ethical and Social Implications of Robotics*, Lin, P., Bekey, G. and Abney, K.eds." Cambridge: MIT Press, 2011.
- [4] S. Agarwal, A. Mohan, and K. Kumar, "Design, Construction And Structure Analysis Of Twinrotor UAV," *Int. J. Instrum. Control Syst.* Jan2014, vol. 4, no. 1, p. 33, 2014.
- [5] H. Skinnemoen, "UAV & satellite communications live mission- critical visual data," in *Aerospace Electronics and Remote Sensing Technology (ICARES)*, 2014 IEEE International Conference on, 2014,pp. 12–19.
- [6] J. Schlesinger and A. Day, "Card Sharks: How ATM skimming has grown more sophisticated", CNBC, 2018. [Online]. Available: <https://www.cnbc.com/2017/09/15/card-sharks-atm-skimminggrows-more-sophisticated.html>. [Accessed: 23- Jul- 2018].
- [7] V. Zoleta, "Old ATM Cards Will Be Discontinued. Here's How You Can Switch to an EMV Card", *Financial News and Advice in the Philippines*, 2018. [Online]. Available: <https://www.moneymax.ph/blog/switch-emvcard-now>. [Accessed: 23- Sep- 2018].
- [8] K. J. Leonard, "The development of a rule based expert system model for fraud alert in consumer credit", *European Journal of Operational Research*, vol. 80, no. 2, pp. 350-356, 1995.
- [9] E. Aleskerov, B. Freisleben and B. Rao, "CARDWATCH: a neural network based database mining system for credit card fraud detection," in *Proc. IEEE/IAFE 1997 Computational Intelligence for Financial Engineering (CIFEr)*, 1997, pp. 220-226.
- [10] N. Philip and K. K. Sherly, "Credit Card Fraud Detection based onBehavior Mining," *TIST International Journal for Science, Technology and Research*, vol. 1, pp. 7-12, 2012.
- [11] T. Guo and G.Y. Li, "Neural data mining for credit card fraud detection,"in *Proc. 2008 International Conference on Machine Learning and Cybernetics*, 2008, pp. 3630-3634.
- [12] K. K. Tangod and G. H. Kulkarni, "Detection of Financial StatementFraud using Data Mining Technique and Performance Analysis," *International Journal of Advanced Research in Computer and Communication Engineering*, vol. 4, no. 7, pp. 549-555, 2015.
- [13] E. Kirkos, C. Spathis and Y. Manolopoulos, "Data Mining techniques for the detection of



fraudulent financial statements,” Expert Systems with Applications, vol. 32, no. 4, pp. 995-1003, 2007.

[14] S. Bhattacharyya, S. Jha, K. Tharakunnel and J. C. Westland, “Datamining for credit card fraud: A comparative study,” Decision Support Systems, vol. 50, no. 3, pp. 602-613, 2011.

[15] J. Akhilomen, “Data Mining Application for Cyber Credit-Card Fraud Detection System”, in Proc. Industrial Conference on Data Mining 2013, vol. 7987, 2013, pp. 218-228.

[16] M. R. Lepoivre, C. O. Avanzini, G. Bignon, L. Legendre, and A. K. Piwele, “Credit Card Fraud Detection with Unsupervised Algorithms,” Journal of Advances in Information Technology, vol. 7, no. 1, pp. 34-38, 2016.

[17] M. Krivko , “A hybrid model for plastic card fraud detection systems,” Expert Systems with Applications, vol. 37, Issue 8, pp. 6070-6076, 2010.